

MODEL K DRAIN CLEANING MACHINE

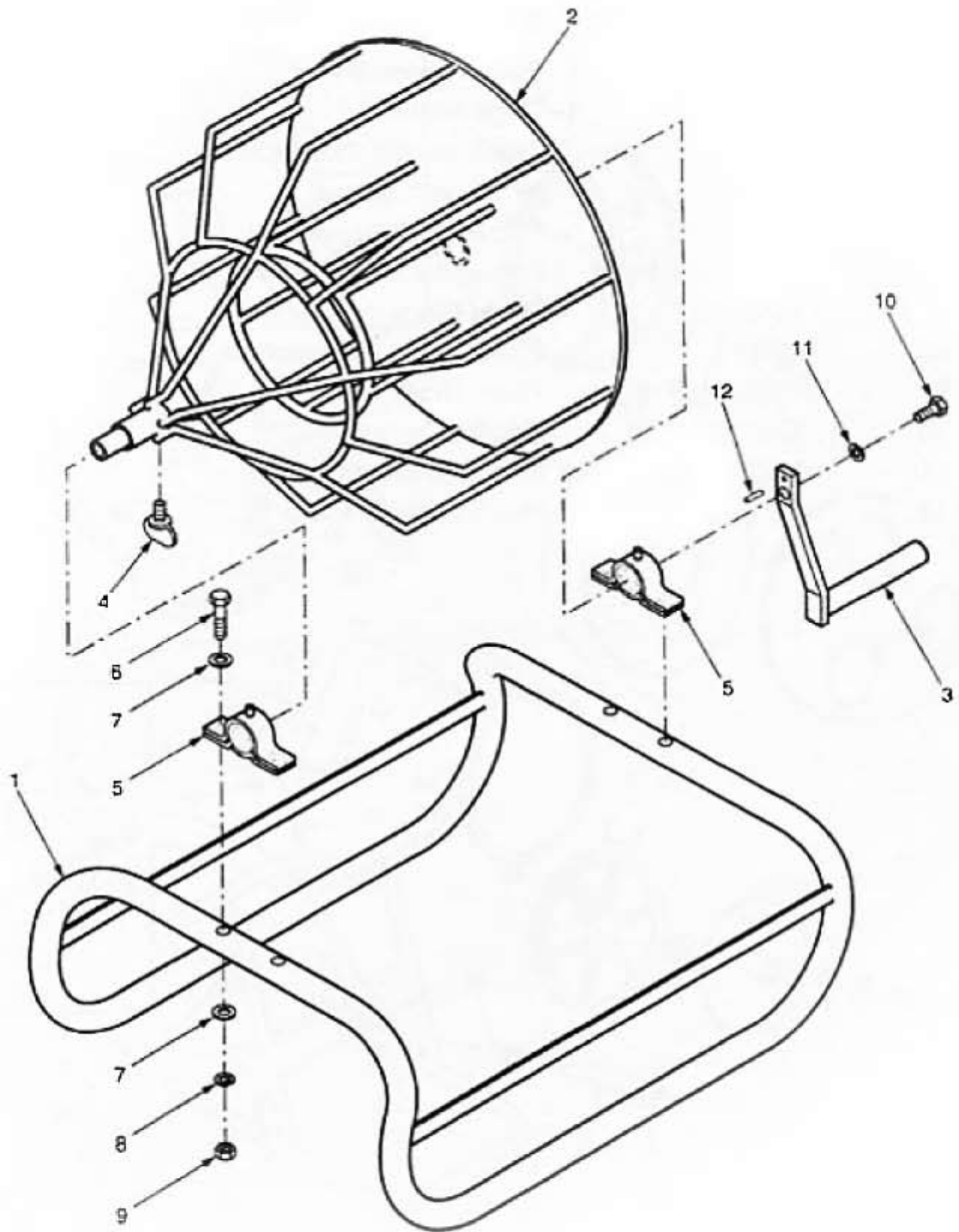

MODEL K – 50' MANUAL

The Model K 50' manual unit utilizes the same 1/2" diameter cable and same tools as the 50' Electric Model E.

MAINTENANCE

- Clean and lubricate cable after each rental
- Oil pillow block periodically

V. HOW TO REPLACE FP-1A FOOT PEDAL AND HOSE ASSEMBLY

1. Remove old clamp from hose at the TBS3218 air switch connection
2. Remove old hose from TBS3218 air switch
3. Slide new clamp onto the new FP-1A foot pedal hose assembly
4. Slide new hose onto the TBS3218 air switch
5. Pinch clamp into TBS3218 air switch

MODEL K DRAIN CLEANING MACHINE

ITEM NUMBER	PART NUMBER	DESCRIPTION	AMT
1	K-1A	Frame Assembly	1
2	K-2A	Cage Assembly	1
3	K-6A	Crank Handle Assembly.	1
4	TX-3/8	3/8" Thumb Screw	1
5	BB816-A	Pillow Block Assembly	2
6	CSHH51618134	Pillow Block Capscrews	4
7	WA516S	Pillow Block Washers.	8
8	LW516	Pillow Block Lockwashers	4
9	NU51618FHP	Pillow Block Nuts.	4
10	CSHH381658	Handle Capscrew	1
11	LW38	Handle Lockwasher	1
12	SP1478	Handle Drive Pin	1